



STAINLESS DESIGN TURBO HAND DRYER

249

IR sensor
High speed
5-year warranty



Stainless Design TURBO is a touch-free, high-speed hand dryer. Stainless Design is a complete product line for commercial toilets, in which quality and aesthetics are paramount. The entire stainless product line is made of strong quality materials, featuring unique design with a beautifully arched housing in brushed stainless steel. The machine comes with a 5-year warranty.

Technical data

Type	STAINLESS DESIGN TURBO HAND DRYER Prod. No.: 249 Touch-free warm-air hand dryer with IR sensor
Dimensions	H: 16.54" x W: 7.87" x D: 7.79"
Material	0.06" brushed stainless steel AISI 304
Drying cycle	10-15 sec.
Connection	110 V, 50/60 Hz, Class I 
Total wattage	1600 W
Heating element	450-900 W
Motor	350-700 W
Noise level	78 dBA
Max. air volume	2.88 yd ³ /min
Max. air capacity	246'-328'/sec.
Max. air outlet temp.	140° F
Net weight	15.18 lb
IP rating	IPX1
Tender text	Touch-free hand dryer with housing in 0.06" brushed, stainless steel. Infra-red sensor and electronic timer, drying cycle 10-15 sec., IPX1, 110 V, 50/60 Hz, 1600 W, Class I (earthed). 78 dBA. Net weight 15.18 lb. H: 16.54" x W: 7.87" x D: 7.79"

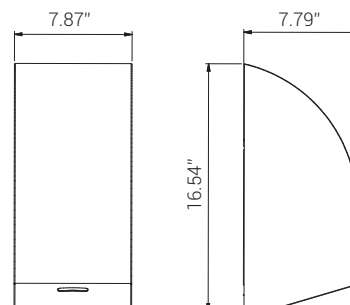

Application

TURBO is a powerful machine and therefore best suited for places with some tolerance of noise. The products are designed specifically for use in public toilets where low maintenance is called for, and equipment must be able to withstand rough treatment.

References

Offices and administration, shopping malls, restaurants, hotels, airports, train stations, sports facilities and public swimming pools, schools, public institutions, and cultural centres.

Standard colour

Brushed stainless steel. Also available in all RAL colours.

Motortype

Commutator motor with carbon brushes. 12,000-18,000 revolutions/min.

Activation

Infrared sensor and electronic timer. Touchfree. Activation distance adjustable between 2.0-11.8". Automatic stop after 60 seconds of continuous use.

Protection

Automatic thermal cut-out in motor and heating element.

Installation

Machine intended for wall-mounting and fixed installation via circuit-breaker. Installation must be carried out by a qualified electrician.

Approval

